

SYMB	REVISION	DATE	APVD.	SYMB	REVISION	DATE	APVD.	VERSION: 2	F4A-52-1/1	
								MODE		
								TIMING	Non-Specified	
								LINE(S)	CIRCUIT	STROKE
								1	1P2T	1.0

Without any banned substance! Compliance with RoHS!

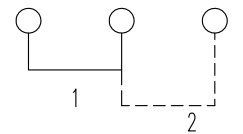
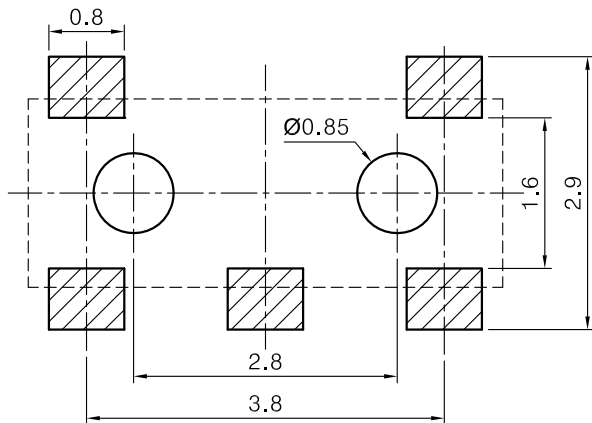
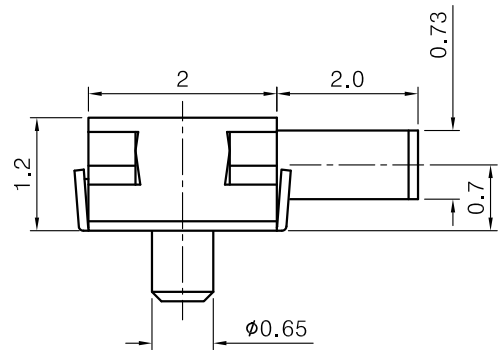
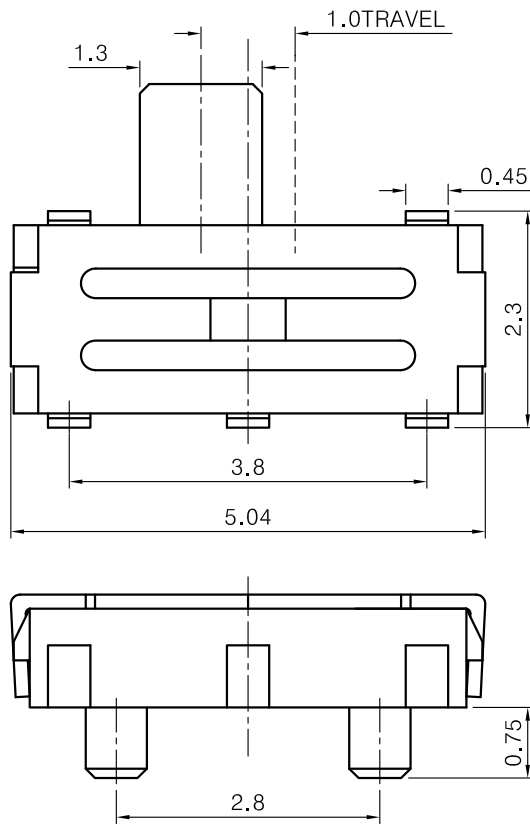

CIRCUIT DIAGRAM

Recommended PAD Layout ± 0.05
TOP VIEW

PACKING DETAIL

<QTY: PCS/REEL>

TYPE	MINI SWITCH	UNIT	mm	9				
SERIES	SKY-12B01	SCALE	5:1	8				
PART NO.	SKY-12B01-G2	DATE	12/03/07	7				
SPEC. NO.	SETD01842	PAGE	1/6	6				
DRAWN	CHECKED	APVD.	TOLERANCE		5	COVER	PHOSPHOR BRONZE	1 Ag PLATED
			ANGLE	$\pm 3^\circ$	4	SLIDER	LCP	1 BLACK
			UP TO 1	± 0.1	3	CONTACT	PHOSPHOR BRONZE	1 Ag CLAD
			ABOVE 1 ~ 5	± 0.2	2	TERMINAL	PHOSPHOR BRONZE	5 Ag PLATED
			ABOVE 5 ~ 50	± 0.3	1	CASE	LCP	1 BLACK
SANWIN ELECTRONIC TECHNOLOGY CO. LTD.					NO.	NAME	MATERIAL	QTY. FINISHING

產品規格書				檔編號No. :	頁數Page	
SPECIFICATION				SKY0004	P1/5	
產品類別Type:	迷你滑動開關Mini Slide Switch			Prepared	Checked	Approved
產品系列Series:	SKY-12B01	版本Version:	0	Q.Z.LI	L.C.Y	Y.ZHAO
產品編號Part No.:	SKY-12B01-G2.0	日期Date:	2011/11/10			
1. 通則 General Characteristics:						
<p>1.1 應用範圍 Application range: 此產品規格書適用於迷你滑動開關SKY-12B01。 This product specification is applied to the SKY-12B01 Mini Slide Switch.</p> <p>1.2 使用環境條件 Acclimatization: 使用溫度範圍 Operating Temperature rang:-20°C ~ 70°C 保存溫度範圍 Preservative Temperature:-30 ~ 80°C</p> <p>1.3 測試條件Test Conditions: 若沒有特別說明，則試驗條件如下： Unless otherwise specified,the atmospheric for marking measurements and tests are as follows: 溫度 Temperature:20±2°C 相對濕度 Relative Humidity:45 ~ 85% 氣壓 Air pressure:86 ~ 106Kpa 如對判定產生疑義，則試驗按以下條件進行： However,if the decision based on the measurements suspicion conditions, the following conditions shall be employed: 溫度 Temperature:20±2°C 相對濕度 Relative Humidity:65±5% 氣壓 Air pressure:86 ~ 106Kpa</p>						
2. 外觀和安裝尺寸 Appearance & Mounting Dimensions:						
<p>2.1 外觀 Appearance: 產品外觀良好，無破損、銹蝕、裂紋和鍍層缺陷。 The switch shall have good finishing,and no rust,crack plating defects.</p> <p>2.2 安裝尺寸Mounting dimensions. 應符合產品設計要求，詳見成品圖。 Should comply with the design requirements of products, see the finished product drawing.</p>						
3. 驅動方式Operate Mode:						
<p>按鈕式：中間方向（如成品圖所示） Push Button:Center (as assembly drawing shown).</p>						
4. 回路方式 Circuit Mode:						
<p>如成品圖所示 (as assembly drawing).</p>						
5. 額定負荷及壽命 Rating and Ooerating life.						
<p>額定負荷 Rating:DC 12V,10mA Max 機械壽命 Mechanical life:10 , 000次</p>						
6 電氣性能Electrical Characteristics						
專案Item	測試條件Test Method			標準Criteria		
6.1 接觸電阻 Contact Resistsnce	以1A 5V DC 或者 1KHz±200Hz(20mV max , 50mA max) 下採用電壓降法測量。 Shall be measure at 1KHZ±200Hz (20mV max,50mA max) or DC 5V 1A by voltage drop method.			常態 Normal 100mΩ以下 500mΩ max 氣候及壽命試以後 After climate and life test. 1000mΩ以下 1000mΩ max		

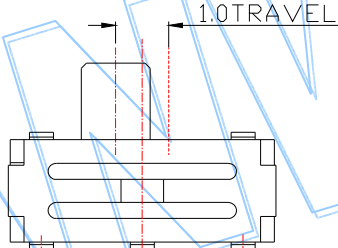
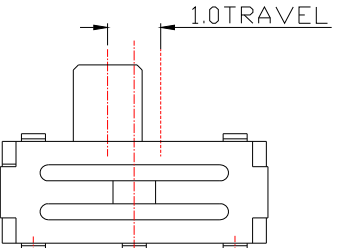
產品規格書				檔編號No. :	頁數Page	
SPECIFICATION				SKY0004	P2/5	
產品類別Type:	迷你滑動開關Mini Slide Switch			Prepared	Checked	Approved
產品系列Series:	SKY-12B01	版本Version:	0	Q.Z.LI	L.C.Y	Y.ZHAO
產品編號Part No.:	SKY-12B01-G2.0	日期Date:	2011/11/10			
6.2 絕緣阻抗 Insulation Resistance	<p>在相互絕緣的所有端子之間及各接線端子與外露的非載流金屬零件之間加載100V DC ,持續時間60±5S.</p> <p>DC 100V voltage is applied between each pair of terminals andbetween the terminal and the metalframefor 60±5S.</p>			<p>常態 Normal 100MΩ以上 100MΩ Min 氣候及壽命試以後 After climate and life test. 10MΩ以上 10MΩmin</p>		
6.3 抗電強度 Dielectric Strength	<p>在相互絕緣的所有接線端子之間加載250V (50 ~ 60Hz洩漏電流10mA) 的交流電，各接線端子與外殼或非載流金屬零件之間加載250V(50 ~ 60Hz)電流 洩漏2mA交流電，持續時間60±5S。</p> <p>AC 250V(50-60Hz)2mA alternate current load is applied between open terminals connected with wires or250V (50-60Hz),2mA Alternate current load for 60±5S.</p>			<p>無擊穿和飛弧現象 The switch without dielectric breakdown and fly arc phenomenon.</p>		
7 機械性能 Mechanical Charateristics						
專案Item	測試條件Test Method			標準 Criteria		
7.1 操作力 Operating Force	<p>按規定的操作方法給操作柄施加壓力 Push by recommended operating condition.</p>			<p>規格Specifications 150±50gf.</p>		
						
7.2 行程 Travels	<p>開關發生轉換後，操作元件末端之間與初始位置之間的距離。 Distance from the end of operating component to the position when switch is being transformed.</p>			<p>距離Distance 1.0±0.2mm</p>		
						

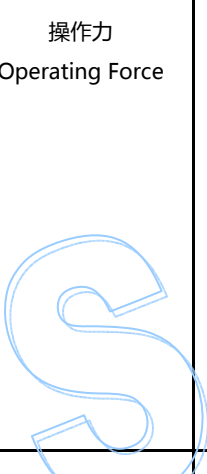

產品規格書				檔編號No. :	頁數Page	
SPECIFICATION				SKY0004	P3/5	
產品類別Type:	迷你滑動開關Mini Slide Switch			Prepared	Checked	Approved
產品系列Series:	SKY-12B01	版本Version:	0	Q.Z.LI	L.C.Y	Y.ZHAO
產品編號Part No.:	SKY-12B01-G2.0	日期Date:	2011/11/10			
7.3 操作件強度 Operating Part Strength	置開關於正常安裝位置，在操作件中心施加與操作件動作相同方向的1kgf靜負荷，時間為60 ±5S。 Put the switch in the normal gearing position,Bring 1kgf pressure which direction is similar to the actuator operates direction in the tip of the actuator center ,time is 60±5S.			無機械和電氣損傷。 The switch shall be free from mechanical and electrical damage.		
7.4 振動 Vibration Proof	開關採用常規安裝方法牢固地安裝在實驗設備上，按下述參數進行實驗： 1) 振頻：10-55Hz 2) 振幅：1.5mm 3) 振動變化速率：10~55~10Hz 大約1分鐘 4) 變頻方法：線形方式 5) 振動方向：三個互相垂直的方向，其中一個方向為操作元件運動的方向。 Switch shall be secured to a testing machine by a normal mounting device and method, Switch shall be measured after following test: 1)Vibration frequency range:10~55Hz. 2) Total amplitude:1.5mm 3)Sweep ratio:10~55~10Hz,Approx 1 minute 4)Method of changing the sweep vibration frequency linear. 5)Direction of vibration:Three perpendicular directions including actuating direction.			符合第6.1、6.2、6.3第7.1條要求。 According to item 6.1、6.2、6.3 and 7.1 to examine.		
7.5 衝擊 Impact shock test	1)加速度 Acceleration：80G 2)衝擊次數：六個方向3次，共18次 2)Cycle of test:3cycles each in 6 directions,for a total 18 cycles.					
8 耐候試驗 Weather Proof Characteristics						
專案Item	測試條件 Test method			標準Criteria		
8.1 高溫 Hot Proof	試件在80±2°C的溫控箱內保持48小時，然後在正常溫度和濕度下恢復1小時，並在此後的1小時內對試件進行測量，水滴應消失。 After testing at 80±2°C for 48 hours,the switch shall be allowed to stand under normal temperature and humidity conditions for 1 hour and measurement shall be made with 1 hour after that,water drops shall be eliminated.			符合第6.1、6.2、6.3第7.1條要求。 According to item 6.1、6.2、6.3 and 7.1to examine.		

產品規格書				檔編號No. :	頁數Page	
SPECIFICATION				SKY0004	P4/5	
產品類別Type:	迷你滑動開關Mini Slide Switch			Prepared	Checked	Approved
產品系列Series:	SKY-12B01	版本Version:	0	Q.Z.LI	L.C.Y	Y.ZHAO
產品編號Part No.:	SKY-12B01-G2.0	日期Date:	2011/11/10			
8.2 恒定濕熱 Moisture Resistance	<p>試件在60±2°C,90~95%RH的溫控箱內保持48小時，然後在正常溫度和濕度下恢復1小時，並在此後的1小時內對試件進行測量，水滴應消失。</p> <p>After testing at 60±2°C,90~95%RH for 48 hours,the switch shall be allowed to stand under normal temperature and humidity conditions for 1 hour and measurement shall be made with 1 hour after that, Water drops shall be eliminated.</p>					
8.3 低溫 Cold Proof	<p>試件在-40±2°C的溫控箱內保持48小時，然後在正常溫度和濕度下恢復1小時，並在此後的1小時內對試件進行測量，水滴應消失。</p> <p>After testing at -40±2°C for 48 hours,the switch shall be allowed to stand under normal temperature and humidity conditions for 1 hour and measurement shall be made with 1 hour after that, water drops shall be eliminated.</p>					
8.4 溫度轉換 Temperature Cycling	<p>試件按下述試驗條件試驗5個迴圈，然後在正常溫度和濕度下恢復1小時，並在此後的1小時內對試件進行測量，水滴應消失。</p> <p>After 5 cycles of following conditions,the switch shall be allowed to stand under normal temperature and humidity conditions for 1 hour after that,Water drops shall be eliminated.</p>			<p>符合第6.1、6.2、6.3第7.1條要求。</p> <p>According to item 6.1、6.2、6.3 and 7.1to examine.</p>		
9 耐久性試驗 Durability Characteristics						
專案Item	測試條件 Test method			標準Criteria		
9.1 壽命試驗 Operating Life	<p>1)在不帶負荷的條件下，在壽命測試設備上連續轉換10,000次，頻率：15-20次/分鐘。</p> <p>1)10,000 cycles of operation shall be performed continuously cycles without load at a rate of 15-20 cycles per minute.</p>			<p>動作力：初始值的±30%</p> <p>Operating force:within ±30% initialization value.</p> <p>彈跳 10 ms max</p> <p>Bounce 10 ms max</p> <p>其餘符合第6.1、6.2、6.3、7.1條</p> <p>Etceteras according to item 6.1, 6.2、6.3,7.1 to examine.</p>		

產品規格書				檔編號No. :	頁數Page
SPECIFICATION				SKY0004	P5/5
產品類別Type:	迷你滑動開關Mini Slide Switch			Prepared	Checked
產品系列Series:	SKY-12B01	版本Version:	0	Q.Z.LI	L.C.Y
產品編號Part No.:	SKY-12B01-G2.0	日期Date:	2011/11/10		

10. 焊接Soldering

專案Item	測試條件 Test method	標準Criteria
101 耐焊接熱 Solder Heat Resistance	<p>試件在下述條件下進行試驗：</p> <p>1) 焊接溫度:260±5°C；</p> <p>2) 焊接時間：5±1S；</p> <p>3) 熔錫面積：PCB板厚度的一半（PCB：t=1.6）。</p> <p>Switch shall be checked in the following conditions test:</p> <p>1)Soldering temperature:260±5°C；</p> <p>2)Soldering time:5±1S；</p> <p>3)Soldering area：1/2 of PCB board thickness(PCB:t=1.6).</p>	<p>無機械和電氣損傷</p> <p>The switch shall be free from mechanical and electrical damage.</p>
10.2 回流焊 Reflow Soldering		<p>外觀無裂開、鬆動等異常現象，滿足於電氣性能。</p> <p>Without deformation of frame or excessive looseness of terminals, Electrical performance shall be satisfied.</p>
10.3 可焊性 Solderbilifty	<p>焊接溫度：260±5°C</p> <p>Solder temperature: 260 ±5°C.</p> <p>浸漬時間：3 ±0.5S</p> <p>Dipping time: 3 ±0.5 second.</p>	<p>超過90%的浸漬覆蓋焊接。</p> <p>More than 90% of the dipping covered by solder.</p>

